

Σ -7-Series AC Servo Drive Σ -7S/ Σ -7W SERVOPACK Supplementary Manual

SERVOPACK with Analog Voltage/Pulse Train References
SERVOPACK with MECHATROLINK-II Communications References
SERVOPACK with MECHATROLINK-III Communications References

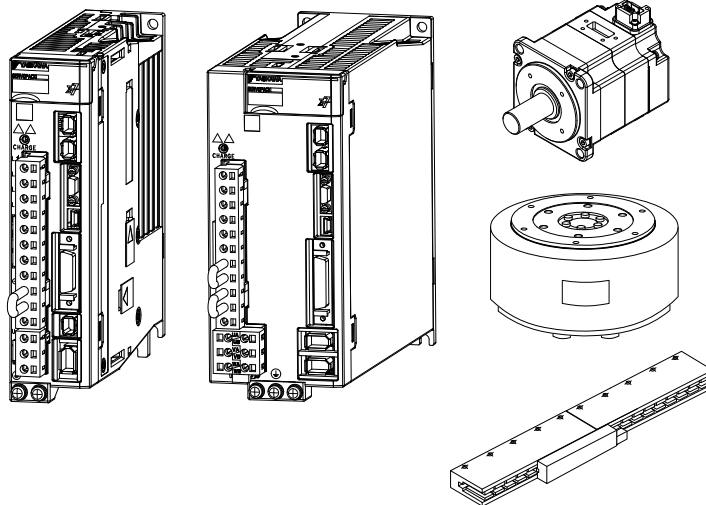

Application Functions

1

Tuning

2

Monitoring

3

Maintenance

4

Copyright © 2014 YASKAWA ELECTRIC CORPORATION

All rights reserved. No part of this publication may be reproduced, stored in a retrieval system, or transmitted, in any form, or by any means, mechanical, electronic, photocopying, recording, or otherwise, without the prior written permission of Yaskawa. No patent liability is assumed with respect to the use of the information contained herein. Moreover, because Yaskawa is constantly striving to improve its high-quality products, the information contained in this manual is subject to change without notice. Every precaution has been taken in the preparation of this manual. Nevertheless, Yaskawa assumes no responsibility for errors or omissions. Neither is any liability assumed for damages resulting from the use of the information contained in this publication.

About this Manual

This manual provides supplementary information for the following manuals.

- Σ -7-Series AC Servo Drive Σ -7S SERVOPACK with Analog Voltage/Pulse Train References Product Manual
- Σ -7-Series AC Servo Drive Σ -7S SERVOPACK with MECHATROLINK-II Communications References Product Manual
- Σ -7-Series AC Servo Drive Σ -7S SERVOPACK with MECHATROLINK-III Communications References Product Manual
- Σ -7-Series AC Servo Drive Σ -7W SERVOPACK with MECHATROLINK-III Communications References Product Manual

Read and understand this manual and the above manual for your SERVOPACK to ensure correct usage of the Σ -7-Series AC Servo Drives.

Outline of Manual

The contents of the chapters of this manual are described in the following table.

Refer to these chapters as required.

Item	This Manual	Σ -7S SERVOPACK Product Manual			Σ -7W SERVOPACK Product Manual		
		SERVOPACK with Analog Voltage/Pulse Train References	SERVOPACK with MECHATROLINK-II Communications References	SERVOPACK with MECHATROLINK-III Communications References	SERVOPACK with MECHATROLINK-III Communications References		
I/O Signal Allocations	–	–	6.1	6.1	6.1	6.1	
Operation for Momentary Power Interruptions	–	–	6.2	6.2	6.2	6.2	
SEMI F47 Function	–	–	6.3	6.3	6.3	6.3	
Motor Maximum Speed Setting	–	–	6.4	6.4	6.4	6.4	
Application Functions	Speed Control	Basic Settings for Speed Control	1.1.1	6.5.1	–	–	–
		Soft Start Settings	–	6.5.2	–	–	–
		Speed Reference Filter	–	6.5.3	–	–	–
		Zero Clamping	–	6.5.4	–	–	–
		/V-CMP (Speed Coincidence Detection Output) Signal	–	6.5.5	–	–	–
	Operation Examples for Changing the Motor Direction	1.1.2	–	–	–	–	–
Position Control	–	–	6.6	–	–	–	

Continued on next page.

Continued from previous page.

Item	This Manual	Σ-7S SERVOPACK Product Manual			Σ-7W SERVOPACK Product Manual
		SERVOPACK with Analog Voltage/Pulse Train References	SERVOPACK with MECHATROLINK-II Communications References	SERVOPACK with MECHATROLINK-III Communications References	SERVOPACK with MECHATROLINK-III Communications References
Torque Control	–	–	6.7	–	–
Encoder Divided Pulse Output	–	–	6.8	6.5	6.5
Software Limits	–	–	–	6.6	6.6
Internal Set Speed Control	–	–	6.9	–	–
Selecting Combined Control Methods	–	–	6.10	–	–
Selecting Torque Limits	–	–	6.11	6.7	6.7
Absolute Rotary Encoders	–	–	6.12	6.8	6.8
Absolute Linear Encoder	–	–	6.13	6.9	6.9
Software Reset	–	–	6.14	6.10	6.10
Vibration Detection Level Initialization	–	–	6.15	6.11	6.11
Motor Current Detection Signal Offset Adjustment	–	–	6.16	6.12	6.12
Forcing the Motor to Stop	FSTP (Forced Stop Input) Signal	1.2.1	–	–	–
	Setting the FSTP (Forced Stop Input) Signal	1.2.2	–	–	–
	Stopping Method Selection for Forced Stops	1.2.3	–	–	–
	Resetting Method for Forced Stops	1.2.4	–	–	–

Continued on next page.

Continued from previous page.

Item			This Manual	Σ-7S SERVOPACK Product Manual			Σ-7W SERVOPACK Product Manual	
				SERVOPACK with Analog Voltage/Pulse Train References	SERVOPACK with MECHATROLINK-II Communications References	SERVOPACK with MECHATROLINK-III Communications References	SERVOPACK with MECHATROLINK-III Communications References	
Tuning	Overview and Flow of Tuning	–	–	8.1	8.1	8.1	8.1	
	Monitoring Methods	–	–	8.2	8.2	8.2	8.2	
	Precautions to Ensure Safe Tuning	–	–	8.3	8.3	8.3	8.3	
	Tuning-less Function	–	–	8.4	8.4	8.4	8.4	
	Moment of Inertia Estimation	–	–	8.5	8.5	8.5	8.5	
	Autotuning without Host Reference	–	–	8.6	8.6	8.6	8.6	
	Autotuning with a Host Reference	–	–	8.7	8.7	8.7	8.7	
	Custom Tuning	–	–	8.8	8.8	8.8	8.8	
	Anti-resonance Control Adjustment	Outline		2.1.1	8.9.1	8.9.1	8.9.1	8.9.1
		Preparations		2.1.2	8.9.2	8.9.2	8.9.2	8.9.2
		Applicable Tools		2.1.3	8.9.3	8.9.3	8.9.3	8.9.3
		Operating Procedure		2.1.4	8.9.4	8.9.4	8.9.4	8.9.4
		Related Parameters		2.1.5	8.9.5	8.9.5	8.9.5	8.9.5
		Suppressing Different Vibration Frequencies with Anti-resonance Control		2.1.6	–	–	–	–
	Vibration Suppression	–	–	8.10	8.10	8.10	8.10	
	Speed Ripple Compensation	Outline		2.2.1	–	–	–	–
		Setting Up Speed Ripple Compensation		2.2.2	–	–	–	–
		Setting Parameters		2.2.3	–	–	–	–
	Additional Adjustment Functions	–	–	8.11	8.11	8.11	8.11	
Manual Tuning	–	–	8.12	8.12	8.12	8.12		
Diagnostic Tools	–	–	8.13	8.13	8.13	8.13		

Continued on next page.

Continued from previous page.

Item			This Manual	Σ-7S SERVOPACK Product Manual			Σ-7W SERVOPACK Product Manual
				SERVOPACK with Analog Voltage/Pulse Train References	SERVOPACK with MECHATROLINK-II Communications References	SERVOPACK with MECHATROLINK-III Communications References	SERVOPACK with MECHATROLINK-III Communications References
Monitoring	Monitoring Product Information	–	–	9.1	9.1	9.1	9.1
	Monitoring SERVOPACK Status	–	–	9.2	9.2	9.2	9.2
	Monitoring Machine Operation Status and Signal Waveforms	–	–	9.3	9.3	9.3	9.3
	Monitoring Product Life	Items That You Can Monitor	3.1.1	9.4.1	9.4.1	9.4.1	9.4.1
Operating Procedure		3.1.2	9.4.2	9.4.2	9.4.2	9.4.2	
Preventative Maintenance		3.1.3	–	–	–	–	
Maintenance	Inspections and Part Replacement	–	–	12.1	12.1	12.1	12.1
	Alarm Displays	List of Alarms	4.1.1	12.2.1	12.2.1	12.2.1	10.2.1
		Troubleshooting Alarms	4.1.2	12.2.2	12.2.2	12.2.2	10.2.2
		Alarm Reset	–	12.2.3	12.2.3	12.2.3	10.2.3
		Displaying Alarm History	–	12.2.4	12.2.4	12.2.4	10.2.4
		Clearing the Alarm History	–	12.2.5	12.2.5	12.2.5	10.2.5
		Resetting Alarms Detected in Option Module	–	12.2.6	12.2.6	12.2.6	10.2.6
	Warning Displays	Resetting Motor Type Alarms	4.1.3	–	–	–	–
		List of Warnings	4.2.1	12.3.1	12.3.1	12.3.1	10.3.1
	Monitoring Communications Data during Alarms or Warnings	Troubleshooting Warnings	4.2.2	12.3.2	12.3.2	12.3.2	10.3.2
–		–	–	12.4	12.4	12.4	10.4
Troubleshooting Based on the Operation and Conditions of the Servomotor	–	–	–	12.5	12.5	12.5	10.5

Using This Manual

◆ Technical Terms Used in This Manual

The following terms are used in this manual.

Term	Meaning
Servomotor	A Σ -7-Series Rotary Servomotor, Direct Drive Servomotor, or Linear Servomotor.
Rotary Servomotor	A generic term used for a Σ -7-Series Rotary Servomotor (SGM7A, SGM7J, or SGM7G) or a Direct Drive Servomotor (SGMCS or SGMCV). The descriptions will specify when Direct Drive Servomotors are excluded.
Linear Servomotor	A Σ -7-Series Linear Servomotor (SGLG, SGLF, SGLT, or SGLC).
SERVOPACK	A Σ -7-Series Σ -7S Servo Amplifier with Analog Voltage/Pulse Train References, Σ -7S Servo Amplifier with MECHATROLINK-II Communications References, Σ -7S Servo Amplifier with MECHATROLINK-III Communications References, or Σ -7W Servo Amplifier with MECHATROLINK-III Communications References.
Servo Drive	The combination of a Servomotor and SERVOPACK.
Servo System	A servo control system that includes the combination of a Servo Drive with a host controller and peripheral devices.
servo ON	Supplying power to the motor.
servo OFF	Not supplying power to the motor.
base block (BB)	Shutting OFF the power supply to the motor by shutting OFF the base current to the power transistor in the SERVOPACK.
servo lock	A state in which the motor is stopped and is in a position loop with a position reference of 0.
Main Circuit Cable	One of the cables that connect to the main circuit terminals, including the Main Circuit Power Supply Cable, Control Power Supply Cable, and Servomotor Main Circuit Cable.
SigmaWin+	The Engineering Tool for setting up and tuning Servo Drives or a computer in which the Engineering Tool is installed.

◆ Differences in Terms for Rotary Servomotors and Linear Servomotors

There are differences in the terms that are used for Rotary Servomotors and Linear Servomotors. This manual primarily describes Rotary Servomotors. If you are using a Linear Servomotor, you need to interpret the terms as given in the following table.

Rotary Servomotors	Linear Servomotors
torque	force
moment of inertia	mass
rotation	movement
forward rotation and reverse rotation	forward movement and reverse movement
CW and CCW pulse trains	forward and reverse pulse trains
rotary encoder	linear encoder
absolute rotary encoder	absolute linear encoder
incremental rotary encoder	incremental linear encoder
unit: min^{-1}	unit: mm/s
unit: N·m	unit: N

Contents

About this Manual	iii
Outline of Manual	iii
Using This Manual	vii

1

Application Functions

1.1	Speed Control	1-2
1.1.1	Basic Settings for Speed Control	1-2
1.1.2	Operation Examples for Changing the Motor Direction	1-8
1.2	Forcing the Motor to Stop	1-10
1.2.1	FSTP (Forced Stop Input) Signal	1-10
1.2.2	Setting the FSTP (Forced Stop Input) Signal	1-11
1.2.3	Stopping Method Selection for Forced Stops	1-14
1.2.4	Resetting Method for Forced Stops	1-15

2

Tuning

2.1	Anti-Resonance Control Adjustment	2-2
2.1.1	Outline	2-2
2.1.2	Preparations	2-3
2.1.3	Applicable Tools	2-3
2.1.4	Operating Procedure	2-3
2.1.5	Related Parameters	2-5
2.1.6	Suppressing Different Vibration Frequencies with Anti-resonance Control	2-5
2.2	Speed Ripple Compensation	2-7
2.2.1	Outline	2-7
2.2.2	Setting Up Speed Ripple Compensation	2-7
2.2.3	Setting Parameters	2-11

3

Monitoring

3.1	Monitoring Product Life	3-2
3.1.1	Items That You Can Monitor	3-2
3.1.2	Operating Procedure	3-2
3.1.3	Preventative Maintenance	3-3

4

Maintenance

4.1	Alarm Displays	4-2
4.1.1	List of Alarms	4-2
4.1.2	Troubleshooting Alarms	4-3
4.1.3	Resetting Motor Type Alarms	4-3

4.2	Warning Displays	4-5
4.2.1	List of Warnings.	4-5
4.2.2	Troubleshooting Warnings	4-5

Revision History

Application Functions



1

This chapter describes the application functions that you can set before you start servo system operation. It also describes the setting methods.

1.1 Speed Control 1-2

- 1.1.1 Basic Settings for Speed Control 1-2
- 1.1.2 Operation Examples for Changing the Motor
Direction 1-8

1.2 Forcing the Motor to Stop 1-10

- 1.2.1 FSTP (Forced Stop Input) Signal 1-10
- 1.2.2 Setting the FSTP (Forced Stop Input) Signal . . . 1-11
- 1.2.3 Stopping Method Selection for Forced Stops . . 1-14
- 1.2.4 Resetting Method for Forced Stops 1-15

1.1 Speed Control

There are two types of speed control: speed control with an analog voltage reference and speed control with internal set speeds. This section describes speed control with an analog voltage reference.

This manual provides the following supplemental information in addition to the information provided in the *Σ-7-Series AC Servo Drive Σ-7S SERVOPACK with Analog Voltage/Pulse Train References Product Manual: /SPD-D (Motor Direction Input) Signal* on page 1-2, *Relation between the /SPD-D (Motor Direction Input) Signal and V-REF (Speed Reference Input) Signal* on page 1-3, and *1.1.2 Operation Examples for Changing the Motor Direction* on page 1-8.

You input a speed reference into the SERVOPACK with an analog voltage to operate the Servomotor at the reference speed.

- If you create a position loop in the host controller, you use the SERVOPACK for speed control.
- If you need to control only the speed of the Servomotor, you use the SERVOPACK for speed control.

You set the control method in Pn000 = n.□□X□ (Control Method Selection).

Set Pn000 to n.□□0□ to set the control method to speed control.

Parameter	Meaning	When Enabled	Classification
Pn000 n.□□0□ (default setting)	Speed control with analog references	After restart	Setup

1.1.1 Basic Settings for Speed Control

This section describes the use of the V-REF (Speed Reference Input) Signal, /SPD-D (Motor Direction Input) Signal, speed reference input gain, and speed reference offset adjustment in speed control with analog voltages.

V-REF (Speed Reference Input) Signal

Input the V-REF (Speed Reference Input) signal to the SERVOPACK to operate the Servomotor at a speed that is proportional to the input voltage.

Type	Signal	Connector Pin No.	Meaning
Input	V-REF	CN1-5	Speed reference input signal
	SG	CN1-6	Signal ground for speed reference input signal

Maximum input voltage: ±12 VDC

If you will use a host controller, such as a programmable controller, for position control, connect the above output pins to the speed reference output terminals on the host controller.

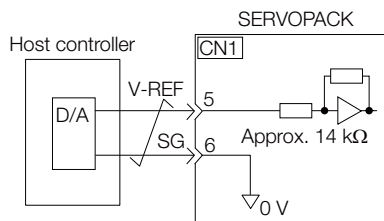

Note: Always use twisted-pair cables to control noise.

/SPD-D (Motor Direction Input) Signal

You can turn the /SPD-D signal ON and OFF to change the direction of the Servomotor.

Classification	Signal	Connector Pin No.	Description
Input	/SPD-D	Must be allocated.	Changes the Servomotor direction.

Note: For information on allocating signals, refer to the product manual for your SERVOPACK.

Relation between the /SPD-D (Motor Direction Input) Signal and V-REF (Speed Reference Input) Signal

The following graphs show the relationship between the V-REF (Speed Reference Input) signal and the speed reference depending on whether the /SPD-D signal is ON or OFF.

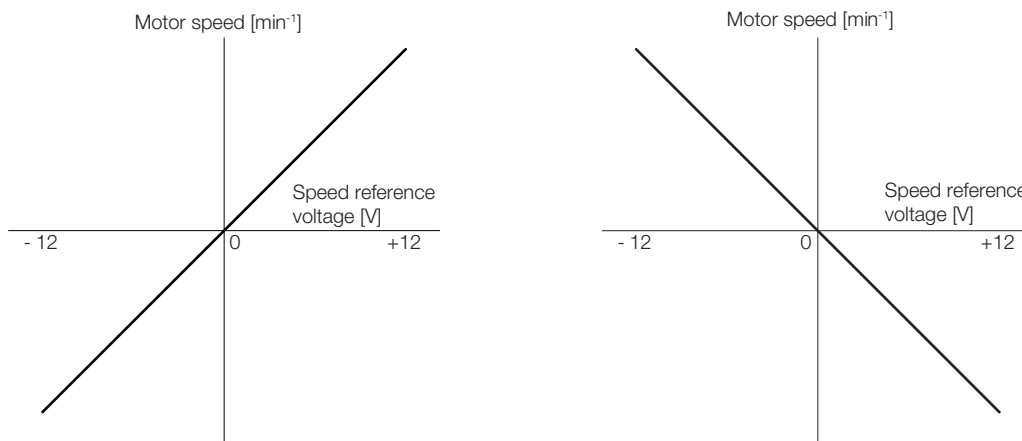

/SPD-D (Motor Direction Input) Signal: OFF

/SPD-D (Motor Direction Input) Signal: ON

Example

Speed Reference Input Example

If Pn300 is set to 600, the motor would operate at the rated speed for 6.00 V.

- For Rotary Servomotors

Speed Reference Input	/SPD-D Signal	Rotation Direction	Motor Speed	For SGM7A Servomotor
+6 V	ON	Reverse	Rated motor speed	-3000 min ⁻¹
	OFF	Forward		3000 min ⁻¹
-3 V	ON	Forward	1/2 of rated motor speed	1500 min ⁻¹
	OFF	Reverse		-1500 min ⁻¹
+1 V	ON	Reverse	1/6 of rated motor speed	-500 min ⁻¹
	OFF	Forward		500 min ⁻¹

Speed Reference Input	/SPD-D Signal	Rotation Direction	Movement Speed	For SGLGW-30A Linear Servomotor
+6 V	ON	Reverse	Rated motor speed	-1500 mm/s
	OFF	Forward		1500 mm/s
-3 V	ON	Forward	1/2 of rated motor speed	750 mm/s
	OFF	Reverse		-750 mm/s
+1 V	ON	Reverse	1/6 of rated motor speed	-250 mm/s
	OFF	Forward		250 mm/s

Setting the Speed Reference Input Gain (Pn300)

The reference voltage for the rated motor speed is set for the speed reference input gain (Pn300) to define the relationship between the position reference voltage and the motor speed.

Pn300	Speed Reference Input Gain			Speed	Position	Torque
	Setting Range	Setting Unit	Default Setting	When Enabled	Classification	
	150 to 3,000	0.01 V	600 (rated speed for 6.00 V)	Immediately	Setup	

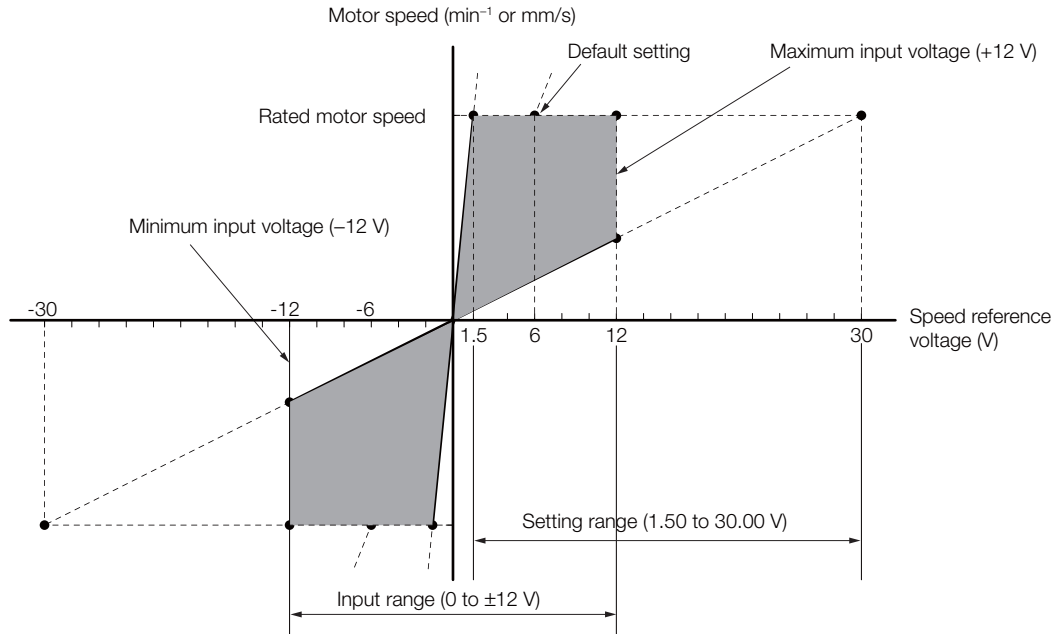

Adjusting the Speed Reference Offset

With speed control, the Servomotor may sometimes rotate at a very low speed for a speed reference of 0 V (with a reference speed of 0 or when the speed reference is stopped). This occurs because the internal reference in the SERVOPACK has a slight offset.

If the Servomotor moves at a very low speed, the offset needs to be eliminated by adjusting the offset.

You can adjust the speed reference offset either automatically or manually.

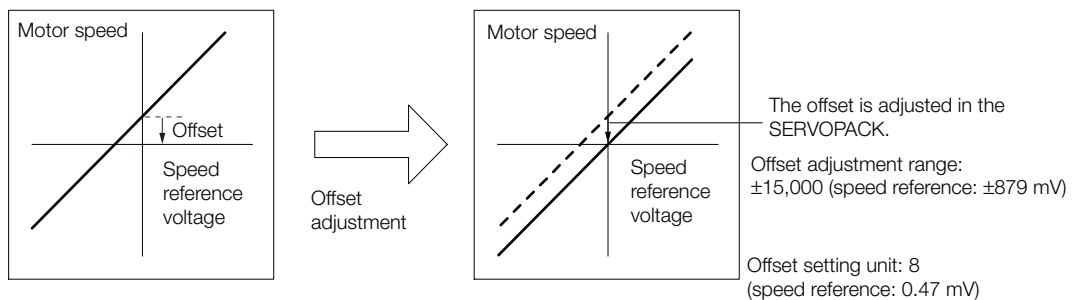

◆ Automatically Adjusting the Speed Reference Offset

To automatically adjust the speed reference offset, the amount of offset is measured and the speed reference voltage is adjusted automatically.

The measured offset is saved in the SERVOPACK.

Information The offset does not use a parameter, so it will not change even if the parameter settings are initialized.

■ **Conditions for Automatically Adjusting the Speed Reference Offset**

The following conditions must be met to automatically adjust the reference offset.

- The parameters must not be write prohibited.
- The servo must be OFF.
- There must not be a position loop in the host controller.

■ **Applicable Tools**

The following table lists the tools that you can use to automatically adjust the speed reference offset and the applicable tool functions.

Tool	Function	Operating Procedure Reference
Panel Operator	Fn009	Σ-7-Series Σ-7S SERVOPACK with Analog Voltage/Pulse Train References Product Manual (Manual No.: SIEP S800001 26)
Digital Operator	Fn013	Σ-7-Series Digital Operator Operating Manual (Manual No.: SIEP S800001 33)
SigmaWin+	Setup - Speed/Torque Reference Offset Adjustment	Operating Procedure on page 1-5

■ **Operating Procedure**

Use the following procedure to automatically adjust the speed reference offset.

1. Confirm that the servo is OFF in the SERVOPACK.
2. Input a 0-V reference voltage from the host controller or an external circuit.

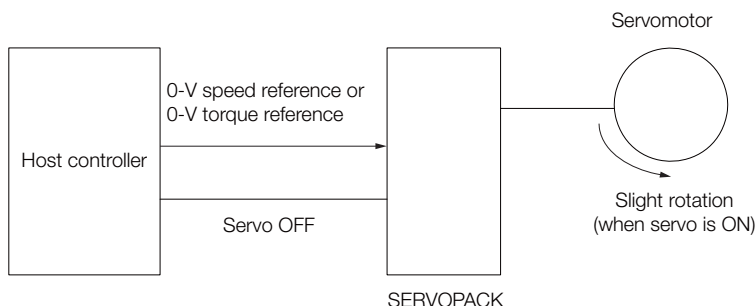

3. Select **Setup - Adjust Offset - Adjust the Speed and Torque Reference Offset** from the menu bar of the Main Window of the SigmaWin+.
4. Click the **Automatic Adjustment** Tab.
5. Click the **Adjust** Button.

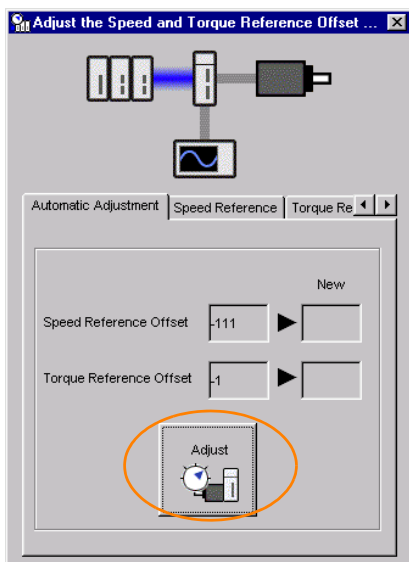

The value that results from automatic adjustment will be displayed in the **New** Box.

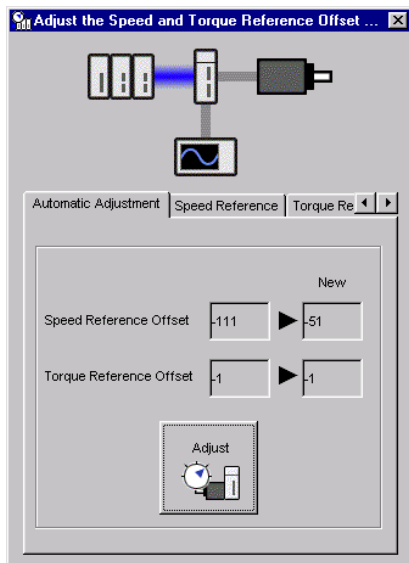

◆ Manually Adjusting the Speed Reference Offset

You can directly input a speed reference offset to adjust the speed reference. The offset is adjusted manually in the following cases.

- When a position loop is created with the host computer and the position deviation when the Servomotor is stopped by a servo lock is to be set to 0
- To intentionally set the offset to a desired value
- To check an offset that was set automatically

Information The offset does not use a parameter, so it will not change even if the parameter settings are initialized.

■ Conditions for Manually Adjusting the Speed Reference Offset

The following conditions must be met to manually adjust the reference offset.

- The parameters must not be write prohibited.
- The servo must be in ready status.

■ Applicable Tools

The following table lists the tools that you can use to manually adjust the speed reference offset and the applicable tool functions.

Tool	Function	Operating Procedure Reference
Panel Operator	Fn00A	Σ-7-Series Σ-7S SERVOPACK with Analog Voltage/Pulse Train References Product Manual (Manual No.: SIEP S800001 26)
Digital Operator	Fn00A	Σ-7-Series Digital Operator Operating Manual (Manual No.: SIEP S800001 33)
SigmaWin+	Setup - Speed/Torque Reference Offset Adjustment	■ Operating Procedure on page 1-7

■ Operating Procedure

Use the following SigmaWin+ procedure to manually adjust the reference offset.

1. Input a 0-V reference voltage from the host controller or an external circuit.

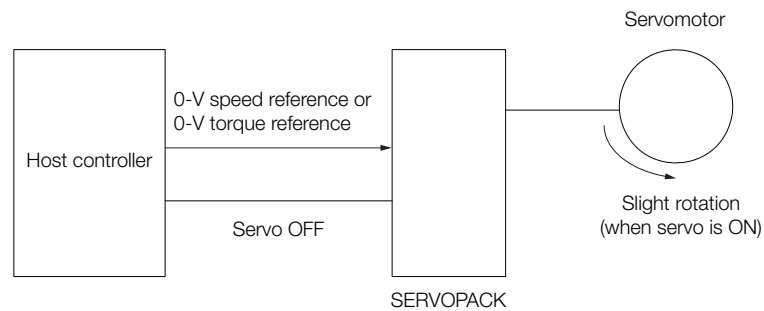

2. Select **Setup - Adjust Offset - Adjust the Speed and Torque Reference Offset** from the menu bar of the Main Window of the SigmaWin+.
3. Click the **Speed Reference** Tab.

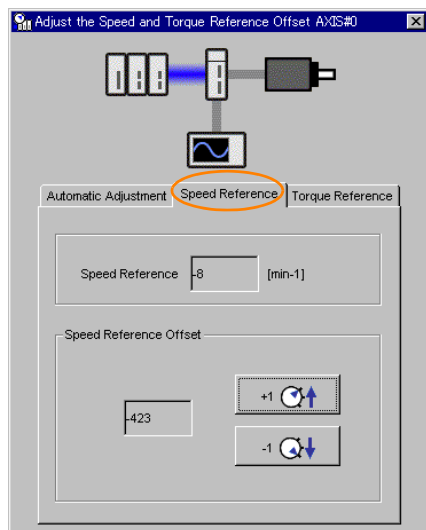

4. Use the +1 and -1 Buttons to adjust the value in the **Speed Reference** Box to 0.

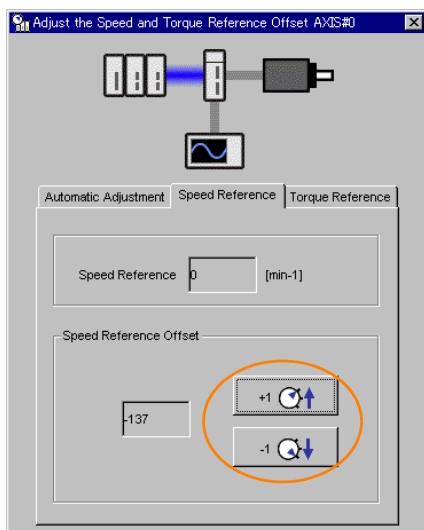

1.1.2 Operation Examples for Changing the Motor Direction

This section describes examples of using the /SPD-D (Motor Direction Input) signal in combination with zero clamping and internal set speed control.

This functionality is provided only in the Σ -7-Series SERVOPACKs with Analog Voltage/Pulse Train References.

Operation Example for Changing the Motor Direction and Zero Clamping

This section provides an example of changing the motor direction without changing the polarity of the speed reference voltage by using the /SPD-D (Motor Direction Input) signal.

/ZCLAMP	/SPD-D	Polarity of Analog Speed Reference Voltage		
		Positive	Zero Clamping Level or Lower ((Pn501 (Pn580))*	Negative
		Rotation Direction	Operating Status	Rotation Direction
OFF	OFF	CCW	Speed Control	CW
OFF	ON	CW	Speed Control	CCW
ON	OFF	CCW	Servo lock (clamped to zero)	CW
ON	ON	CW	Servo lock (clamped to zero)	CCW

* Pn501 (Zero Clamping Level): Used with a Rotary Servomotor.
 Pn580 (Zero Clamping Level): Used with a Linear Servomotor.

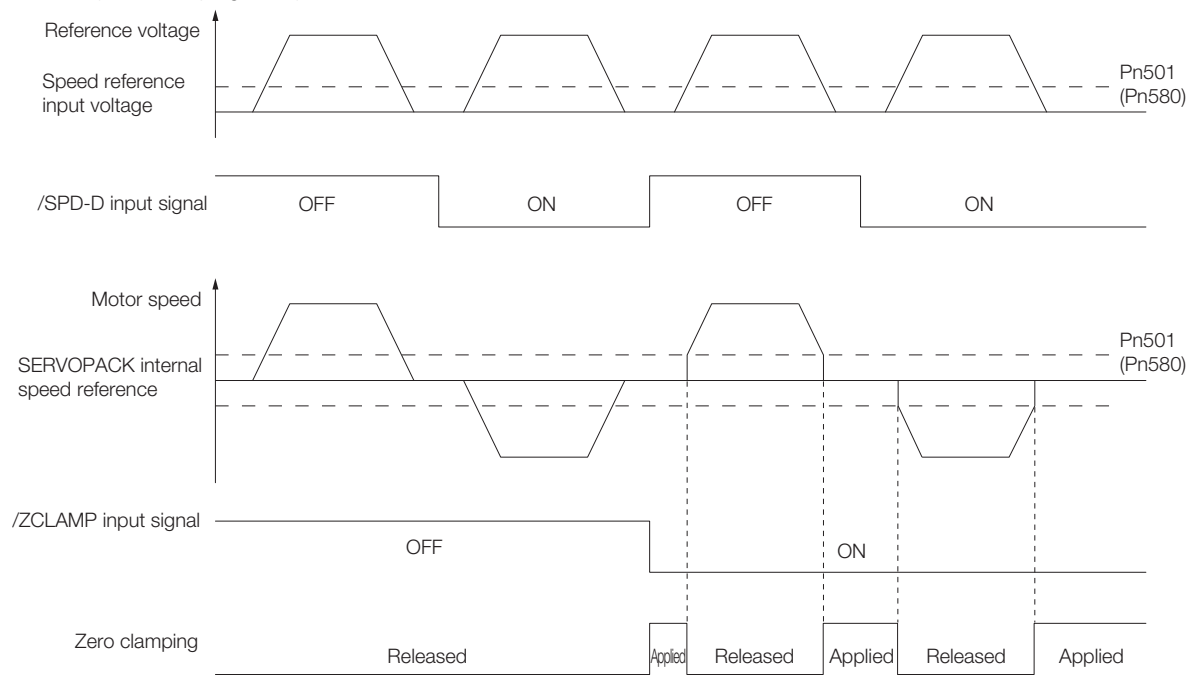

Note: The soft start function is used for the acceleration/deceleration time of the speed reference.

Operation Example for Changing the Motor Direction and Internal Set Speed Control

Even with a speed reference with the same polarity, you can change the motor direction and stop the Servomotor by changing the control mode to internal set speed control and combining the /SPD-D (Motor Direction Input) signal and /C-CEL (Control Selection Input) signal.

The following operation example combines internal set speed control, the /SPD-D signal, and the /C-CEL signal. For this example, the internal set speeds must be set to 0.

◆ Parameter Settings

You must make the following parameter settings to combine internal set speed control, the /SPD-D signal, and the /C-CEL signal.

- Set Pn000 = n.□□X□ (Control Method Selection) to 4 (Switching between internal set speed control and speed control).
- Set Pn305 (Soft Start Acceleration Time) to the required acceleration time.
- Set Pn306 (Soft Start Deceleration Time) to the required deceleration time.
- Set Pn50A = n.□□□X (Input Signal Allocation Mode) to 1 (Change the sequence input signal allocations).
- Set Pn50C = n.□□□X (/SPD-D (Motor Direction) Signal Allocation) to any setting other than 7 (the signal is always active) or 8 (the signal is always inactive).
- Set Pn50C = n.□□X□ (/SPD-A (Internal Set Speed Selection Input) Signal Allocation) to 8 (the signal is always inactive).
- Set Pn50C = n.□X□□ (/SPD-B (Internal Set Speed Selection Input) Signal Allocation) to 8 (the signal is always inactive).
- Set Pn50C = n.X□□□ (/C-SEL (Control Selection Input) Signal Allocation) to any setting other than 7 (the signal is always active) or 8 (the signal is always inactive).

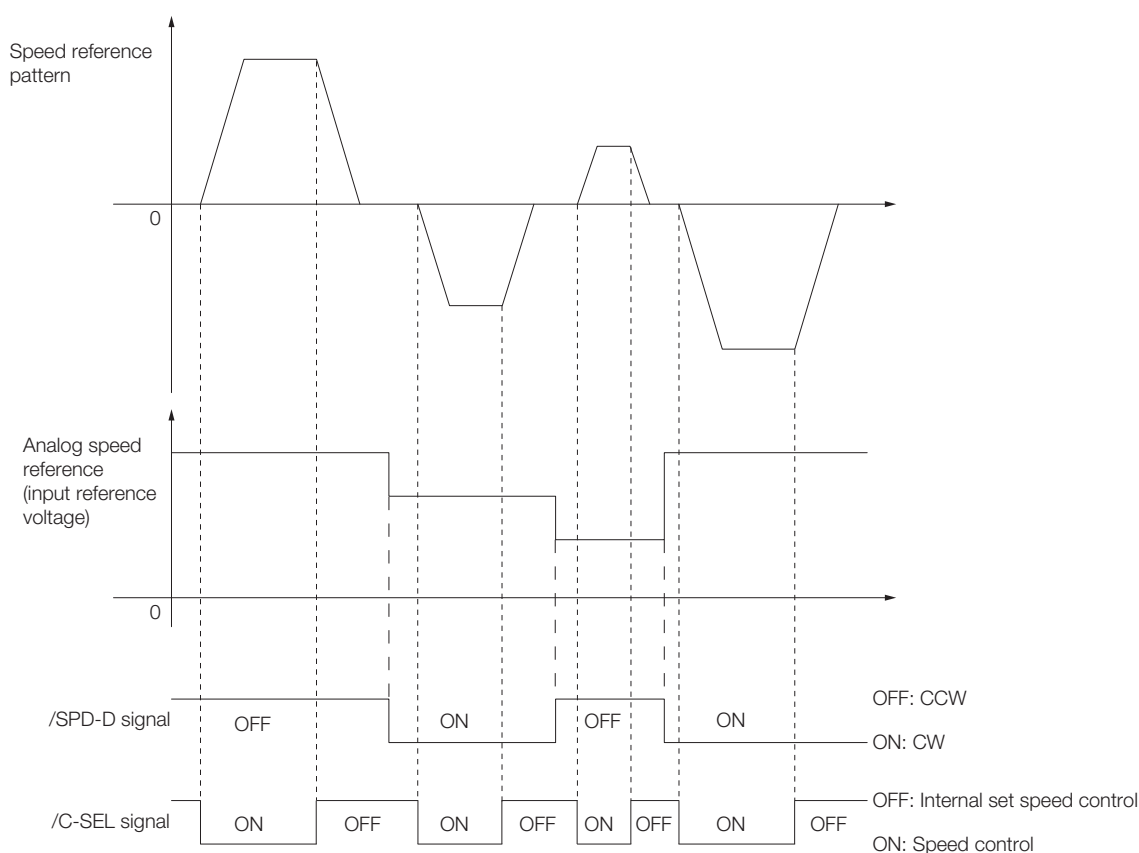

1.2 Forcing the Motor to Stop

You can force the Servomotor to stop for a signal from the host controller or an external device. To force the motor to stop, you must allocate the FSTP (Forced Stop Input) signal in Pn516 = n.□□□X. You can specify one of the following stopping methods: dynamic brake (DB), coasting to a stop, or decelerating to a stop.

Note: Forcing the motor to stop is not designed to comply with any safety standard. In this respect, it is different from the hard wire base block (HWBB).

Information **Panel Operator and Digital Operator Displays**
 For a SERVOPACK with Analog Voltage/Pulse Train References, the Panel Operator will display FST and the Digital Operator will display FSTP.
 For a SERVOPACK with MECHATROLINK-II or MECHATROLINK-III References, the panel and the Digital Operator will display FSTP.

This functionality is supported by the following SERVOPACKs.

- Σ-7S SERVOPACKs with Analog Voltage/Pulse Train References
- Σ-7S SERVOPACKs with MECHATROLINK-II Communications References
- Σ-7S SERVOPACKs with MECHATROLINK-III Communications References
- Σ-7W SERVOPACKs with MECHATROLINK-III Communications References

 **CAUTION**

- To prevent accidents that may result from contact faults or disconnections, use a normally closed switch for the Forced Stop Input signal.

1.2.1 FSTP (Forced Stop Input) Signal

Classification	Signal	Connector Pin No.	Signal Status	Description
Input	FSTP	Must be allocated.	ON (closed)	Drive is enabled (normal operation).
			OFF (open)	The motor is stopped.

Note: Refer to the following section for details on allocations.

 1.2.2 Setting the FSTP (Forced Stop Input) Signal on page 1-11

1.2.2 Setting the FSTP (Forced Stop Input) Signal

When you allocate the FSTP (Forced Stop Input) signal, the forced stop function will be enabled. Use Pn516 = n.□□□X (FSTP (Forced Stop Input) Signal Allocation) to allocate the FSTP signal to a connector pin.

- Σ -7S SERVOPACKs with Analog Voltage/Pulse Train References

Parameter	Description	When Enabled	Classification
Pn516	n.□□□0	Enable drive when CN1-40 input signal is ON (closed).	After restart Setup
	n.□□□1	Enable drive when CN1-41 input signal is ON (closed).	
	n.□□□2	Enable drive when CN1-42 input signal is ON (closed).	
	n.□□□3	Enable drive when CN1-43 input signal is ON (closed).	
	n.□□□4	Enable drive when CN1-44 input signal is ON (closed).	
	n.□□□5	Enable drive when CN1-45 input signal is ON (closed).	
	n.□□□6	Enable drive when CN1-46 input signal is ON (closed).	
	n.□□□7	Set the signal to always prohibit drive (always force the motor to stop).	
	n.□□□8 (default setting)	Set the signal to always enable drive (always disable forcing the motor to stop).	
	n.□□□9	Enable drive when CN1-40 input signal is OFF (open).	
	n.□□□A	Enable drive when CN1-41 input signal is OFF (open).	
	n.□□□B	Enable drive when CN1-42 input signal is OFF (open).	
	n.□□□C	Enable drive when CN1-43 input signal is OFF (open).	
	n.□□□D	Enable drive when CN1-44 input signal is OFF (open).	
	n.□□□E	Enable drive when CN1-45 input signal is OFF (open).	
n.□□□F	Enable drive when CN1-46 input signal is OFF (open).		

- Σ -7S SERVOPACKs with MECHATROLINK-II Communications References or Σ -7S SERVOPACKs with MECHATROLINK-III Communications References

Parameter	Description	When Enabled	Classification
Pn516	n.□□□0	Enable drive when CN1-13 input signal is ON (closed).	After restart Setup
	n.□□□1	Enable drive when CN1-7 input signal is ON (closed).	
	n.□□□2	Enable drive when CN1-8 input signal is ON (closed).	
	n.□□□3	Enable drive when CN1-9 input signal is ON (closed).	
	n.□□□4	Enable drive when CN1-10 input signal is ON (closed).	
	n.□□□5	Enable drive when CN1-11 input signal is ON (closed).	
	n.□□□6	Enable drive when CN1-12 input signal is ON (closed).	
	n.□□□7	Set the signal to always prohibit drive (always force the motor to stop).	
	n.□□□8 (default setting)	Set the signal to always enable drive (always disable forcing the motor to stop).	
	n.□□□9	Enable drive when CN1-13 input signal is OFF (open).	
	n.□□□A	Enable drive when CN1-7 input signal is OFF (open).	
	n.□□□B	Enable drive when CN1-8 input signal is OFF (open).	
	n.□□□C	Enable drive when CN1-9 input signal is OFF (open).	
	n.□□□D	Enable drive when CN1-10 input signal is OFF (open).	
	n.□□□E	Enable drive when CN1-11 input signal is OFF (open).	
n.□□□F	Enable drive when CN1-12 input signal is OFF (open).		

1.2 Forcing the Motor to Stop

1.2.2 Setting the FSTP (Forced Stop Input) Signal

- Σ -7W SERVOPACKs with MECHATROLINK-III Communications References
 For a Σ -7W SERVOPACK, you can set either Pn516 = n.□□□X or Pn597 = n.□XXX to allocate the FSTP signal. To allocate the FSTP signals, always set either Pn516 = n.□□□X or Pn597 = n.□XXX.

Parameter	Description	When Enabled	Classification
Pn516	n.□□□0	Axis A: Enable drive when CN1-3 input signal is ON (closed). Axis B: Enable drive when CN1-9 input signal is ON (closed).	After restart Setup
	n.□□□1	Axis A: Enable drive when CN1-4 input signal is ON (closed). Axis B: Enable drive when CN1-10 input signal is ON (closed).	
	n.□□□2	Axis A: Enable drive when CN1-5 input signal is ON (closed). Axis B: Enable drive when CN1-11 input signal is ON (closed).	
	n.□□□3	Axis A: Enable drive when CN1-6 input signal is ON (closed). Axis B: Enable drive when CN1-12 input signal is ON (closed).	
	n.□□□4	Axis A: Enable drive when CN1-7 input signal is ON (closed). Axis B: Enable drive when CN1-13 input signal is ON (closed).	
	n.□□□5	Axis A: Enable drive when CN1-8 input signal is ON (closed). Axis B: Enable drive when CN1-14 input signal is ON (closed).	
	n.□□□6	Reserved setting (Do not use.)	
	n.□□□7	Set the signal to always prohibit drive (always force the motor to stop).	
	n.□□□8 (default setting)	Set the signal to always enable drive (always disable forcing the motor to stop).	
	n.□□□9	Axis A: Enable drive when CN1-3 input signal is OFF (open). Axis B: Enable drive when CN1-9 input signal is OFF (open).	
	n.□□□A	Axis A: Enable drive when CN1-4 input signal is OFF (open). Axis B: Enable drive when CN1-10 input signal is OFF (open).	
	n.□□□B	Axis A: Enable drive when CN1-5 input signal is OFF (open). Axis B: Enable drive when CN1-11 input signal is OFF (open).	
	n.□□□C	Axis A: Enable drive when CN1-6 input signal is OFF (open). Axis B: Enable drive when CN1-12 input signal is OFF (open).	
	n.□□□D	Axis A: Enable drive when CN1-7 input signal is OFF (open). Axis B: Enable drive when CN1-13 input signal is OFF (open).	
	n.□□□E	Axis A: Enable drive when CN1-8 input signal is OFF (open). Axis B: Enable drive when CN1-14 input signal is OFF (open).	
n.□□□F	Reserved setting (Do not use.)		

Parameter		Description	When Enabled	Classification
Pn597	n.□003	Allocate the signal to CN1-3.	After restart	Setup
	n.□004	Allocate the signal to CN1-4.		
	n.□005	Allocate the signal to CN1-5.		
	n.□006	Allocate the signal to CN1-6.		
	n.□007	Allocate the signal to CN1-7.		
	n.□008	Allocate the signal to CN1-8.		
	n.□009	Allocate the signal to CN1-9.		
	n.□010	Allocate the signal to CN1-10.		
	n.□011	Allocate the signal to CN1-11.		
	n.□012	Allocate the signal to CN1-12.		
	n.□013	Allocate the signal to CN1-13.		
	n.□014	Allocate the signal to CN1-14.		
	n.0□□□ (default setting)	Set the signal to always enable drive (always disable forcing the motor to stop).		
	n.1□□□	Enable drive when the input signal is ON (closed).		
	n.2□□□	Enable drive when the input signal is OFF (open).		
n.3□□□	Set the signal to always prohibit drive (always force the motor to stop).			

1.2.3 Stopping Method Selection for Forced Stops

Use Pn00A = n.□□X□ (Stopping Method for Forced Stops) to set the stopping method for forced stops.

Parameter		Description	When Enabled	Classification
Pn00A	n.□□0□	Apply the dynamic brake or coast the motor to a stop (use the stopping method set in Pn001 = n.□□□X).	After restart	Setup
	n.□□1□	Decelerate the motor to a stop using the torque set in Pn406 as the maximum torque. Use the setting of Pn001 = n.□□□X for the status after stopping.		
	n.□□2□	Decelerate the motor to a stop using the torque set in Pn406 as the maximum torque and then let the motor coast.		
	n.□□3□	Decelerate the motor to a stop using the deceleration time set in Pn30A. Use the setting of Pn001 = n.□□□X for the status after stopping.		
	n.□□4□	Decelerate the motor to a stop using the deceleration time set in Pn30A and then let the motor coast.		

Note: You cannot decelerate a Servomotor to a stop during torque control. For torque control, the Servomotor will be stopped with the dynamic braking or coast to a stop according to the setting of Pn001 = n.□□□X (Servo OFF or Alarm Group 1 Stopping Method).

Stopping the Servomotor by Setting Emergency Stop Torque (Pn406)

To stop the Servomotor by setting emergency stop torque, set Pn406 (Emergency Stop Torque).

If Pn001 = n.□□X□ is set to 1 or 2, the Servomotor will be decelerated to a stop using the torque set in Pn406 as the maximum torque.

The default setting is 800%. This setting is large enough to allow you to operate the Servomotor at the maximum torque. However, the maximum emergency stop torque that you can actually use is the maximum torque of the Servomotor.

Pn406	Emergency Stop Torque			Speed	Position	Torque
	Setting Range	Setting Unit	Default Setting	When Enabled	Classification	
	0 to 800	1%*	800	Immediately	Setup	

* Set a percentage of the motor rated torque.

Stopping the Servomotor by Setting the Deceleration Time for Servo OFF and Forced Stops (Pn30A)

To specify the Servomotor deceleration time and use it to stop the Servomotor, set Pn30A (Deceleration Time for Servo OFF and Forced Stops).

Pn30A	Deceleration Time for Servo OFF and Forced Stops			Speed	Position
	Setting Range	Setting Unit	Default Setting	When Enabled	Classification
	0 to 10,000	1 ms	0	Immediately	Setup

If you set Pn30A to 0, the Servomotor will be stopped with a zero speed.

The deceleration time that you set in Pn30A is the time to decelerate the motor from the maximum motor speed.

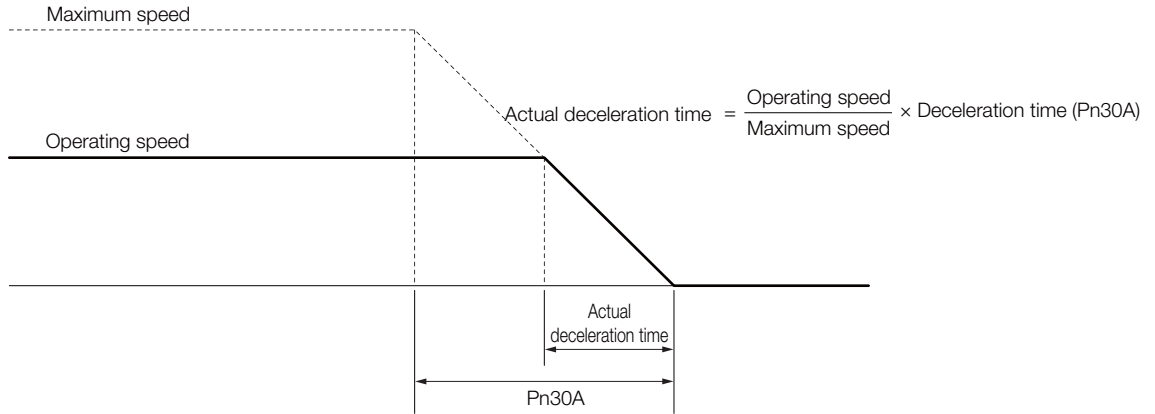

1.2.4 Resetting Method for Forced Stops

This section describes the reset methods that can be used after stopping operation for an FSTP (Forced Stop Input) signal.

If the FSTP (Forced Stop Input) signal is OFF and the /S-ON (Servo ON Input) signal is input, the forced stop state will be maintained even after the FSTP signal is turned ON.

Turn OFF the /S-ON signal to place the SERVOPACK in the base block (BB) state and then turn ON the /S-ON signal again.

- Σ -7S SERVOPACKs with Analog Voltage/Pulse Train References

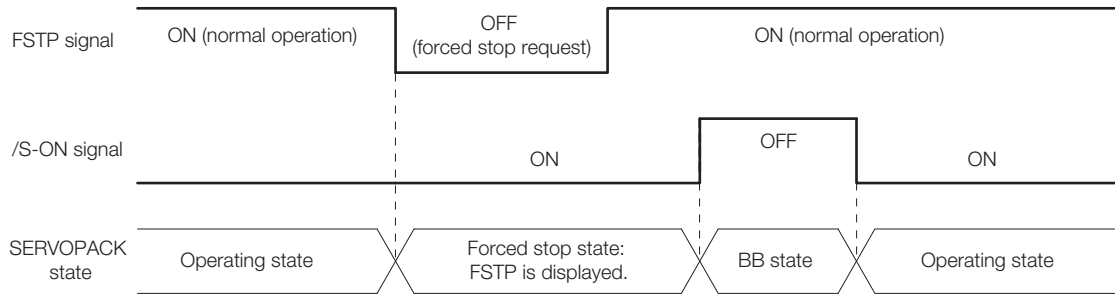

- For a Σ -7S SERVOPACK with MECHATROLINK-II Communications References, Σ -7S SERVOPACK with MECHATROLINK-III Communications References, or Σ -7W SERVOPACK with MECHATROLINK-III Communications References

If the FSTP (Forced Stop Input) signal is OFF and the SV_ON (Servo ON) command is sent, the forced stop state will be maintained even after the FSTP signal is turned ON.

Send the SV_OFF (Servo OFF) command to place the SERVOPACK in the base block (BB) state and then send the SV_ON (Servo ON) command.

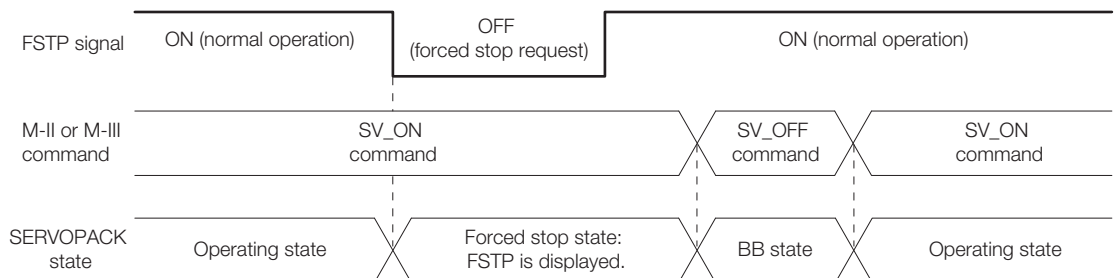

Tuning

2

This chapter provides information on the flow of tuning, details on tuning functions, and related operating procedures.

2.1 Anti-Resonance Control Adjustment 2-2

- 2.1.1 Outline 2-2
- 2.1.2 Preparations 2-3
- 2.1.3 Applicable Tools 2-3
- 2.1.4 Operating Procedure 2-3
- 2.1.5 Related Parameters 2-5
- 2.1.6 Suppressing Different Vibration Frequencies
with Anti-resonance Control 2-5

2.2 Speed Ripple Compensation 2-7

- 2.2.1 Outline 2-7
- 2.2.2 Setting Up Speed Ripple Compensation 2-7
- 2.2.3 Setting Parameters 2-11

2.1 Anti-Resonance Control Adjustment

This section describes anti-resonance control.

This manual provides the following supplemental information in addition to the information provided in the following product manuals: *2.1.6 Suppressing Different Vibration Frequencies with Anti-resonance Control* on page 2-5.

- Σ -7S SERVOPACKs with Analog Voltage/Pulse Train References
- Σ -7S SERVOPACKs with MECHATROLINK-II Communications References
- Σ -7S SERVOPACKs with MECHATROLINK-III Communications References
- Σ -7W SERVOPACKs with MECHATROLINK-III Communications References

2.1.1 Outline

Anti-resonance control increases the effectiveness of vibration suppression after custom tuning.

Anti-resonance control is effective for suppression of continuous vibration frequencies from 100 to 1,000 Hz that occur when the control gain is increased. Vibration can be eliminated by setting vibration frequencies through automatic detection or by manually setting them to adjust the damping gain. Input an operation reference and execute this anti-resonance control adjustment when there is vibration.

Anti-resonance control is automatically set by autotuning without a host reference or autotuning with a host reference. Use anti-resonance control adjustment only if fine-tuning is required or readjustment is required as a result of a failure to detect vibration.

Perform custom tuning if required to increase the response after performing anti-resonance control adjustment. If the control gain is increased, e.g., when custom tuning is performed, vibration may occur again. If that occurs, perform anti-resonance control adjustment again to fine-tune the parameters.

CAUTION

- Related parameters will be set automatically when anti-resonance control adjustment is executed. This may greatly affect the response before and after execution. Make sure that you can perform an emergency stop at any time.
- Before you execute anti-resonance control adjustment, set the correct moment of inertia ratio (Pn103). If the setting greatly differs from the actual moment of inertia ratio, normal control of the machine may not be possible, and vibration may occur.



Important

- Anti-resonance control adjustment detects vibration frequencies between 100 Hz and 1,000 Hz. If the vibration frequency is not within this range, use custom tuning with tuning mode 2 selected to automatically set a notch filter or use vibration suppression.
- Vibration reduction can be made more effective by increasing the anti-resonance damping gain (Pn163), but the vibration may become larger if the damping gain is too high. Increase the damping gain by approximately 0% to 200% in 10% increments while checking the effect on vibration. If vibration reduction is still insufficient at a gain of 200%, cancel the setting, and lower the control gain by using a different method, such as custom tuning.



2.1.2 Preparations

Check the following settings before you execute anti-resonance control adjustment.

- The tuning-less function must be disabled (Pn170 = n.□□□0).
- The test without a motor function must be disabled (Pn00C = n.□□□0).
- The control method must not be set to torque control.
- The parameters must not be write prohibited.

2.1.3 Applicable Tools

The following table lists the tools that you can use to perform anti-resonance control adjustment and the applicable tool functions.

Tool	Function	Operating Procedure Reference
Panel Operator	You cannot execute anti-resonance control adjustment from the Panel Operator.	
Digital Operator	Fn204	 Σ-7-Series Digital Operator Operating Manual (Manual No.: SIEP S800001 33)
SigmaWin+	<i>Tuning - Tuning</i>	 2.1.4 Operating Procedure on page 2-3

2.1.4 Operating Procedure

To execute anti-resonance control adjustment, an operation reference is input, and the adjustment is executed while vibration is occurring.

The following methods can be used to execute anti-resonance control adjustment.

- To automatically detect the vibration frequency
- To manually set the vibration frequency

Use the following procedure.

CAUTION

- Before you execute anti-resonance control adjustment, check the information provided in the SigmaWin+ operating manual. Observe the following precautions.
 - Make sure that you can perform an emergency stop at any time. Parameters will be set automatically when anti-resonance control adjustment is executed. This may greatly affect the response before and after execution. Make sure that you can perform an emergency stop (to turn OFF the power supply) at any time.
 - Set the moment of inertia correctly before you execute anti-resonance control adjustment. If the setting greatly differs from the actual moment of inertia, effective vibration reduction may not be possible.
 - If you have already performed anti-resonance control adjustment and then you change the frequency, the current anti-resonance control effect may be lost. Caution is particularly required when automatically detecting the vibration frequency.
 - If effective vibration reduction is not achieved even after you execute anti-resonance control adjustment, cancel the function and lower the control gain by using a different method, such as custom tuning.
 - Perform custom tuning separately if required to increase the response after performing anti-resonance control adjustment. If the servo gain is increased, e.g., when custom tuning is performed, vibration may occur again. If that occurs, perform anti-resonance control adjustment again to fine-tune the parameters.

1. Perform steps 1 to 7 of the procedure for custom tuning.

For details, refer to the manual for your SERVOPACK.

2. Click the Anti-res Ctrl Adj Button.

The rest of the procedure depends on whether you know the vibration frequency.

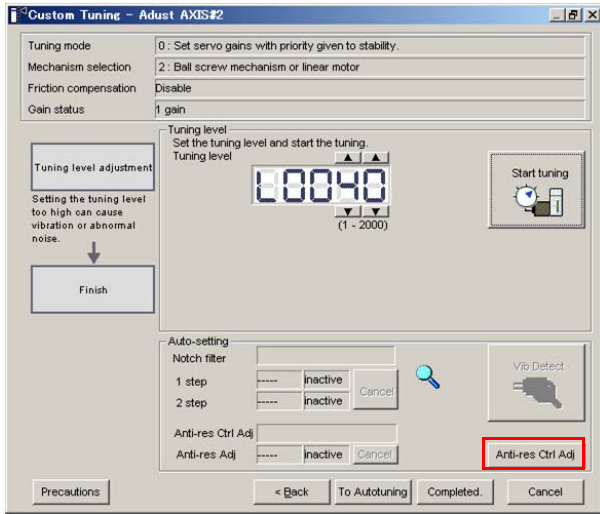

3. If you do not know the vibration frequency, click the Auto Detect Button. If you know the vibration frequency, click the Manual Set Button.

To Automatically Detect the Vibration Frequency

The frequency will be set.

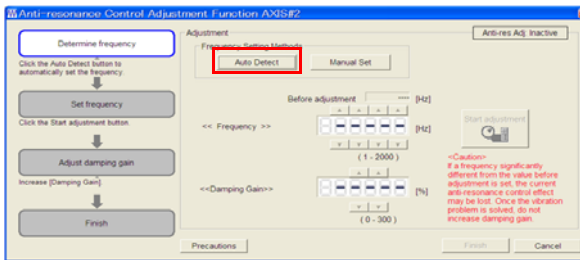

To Manually Set the Vibration Frequency

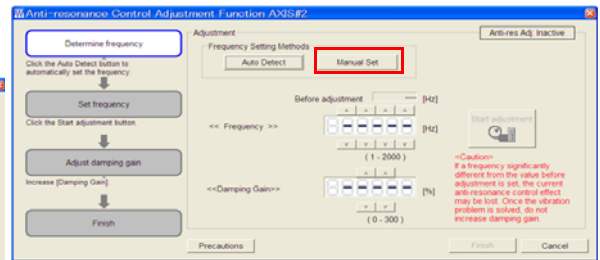

4. Click the Start adjustment Button.

5. Use the ▲ and ▼ Buttons in the Adjustment Area to change the settings.

Click the **Reset** Button during tuning to restore the setting to its original value. The tuning level will return to the value from before when custom tuning was started.

To Automatically Detect the Vibration Frequency

Change the setting of the damping gain.

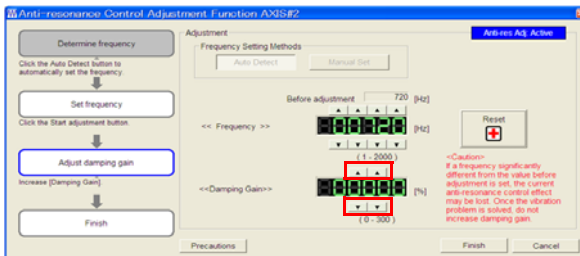

To Manually Set the Vibration Frequency

Change the settings of the frequency and damping gain.

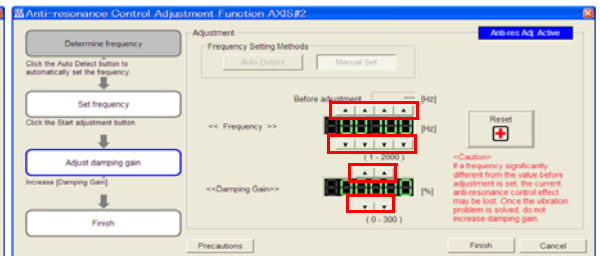

6. When the adjustment has been completed, click the Finish Button.

The values that were changed will be saved in the SERVOPACK and you will return to the Tuning Dialog Box.

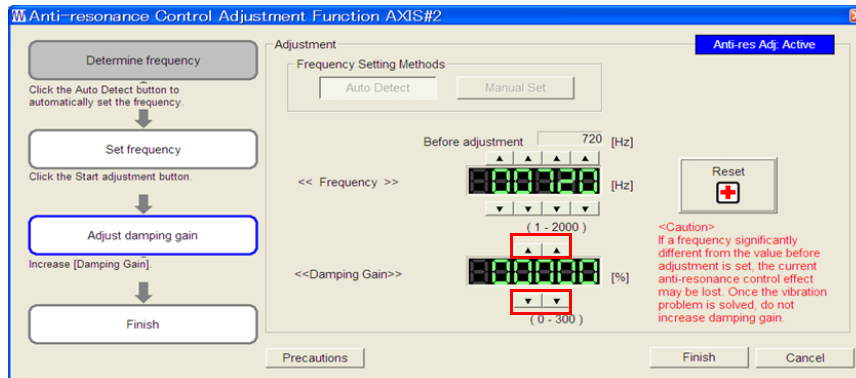

This concludes the procedure.

2.1.5 Related Parameters

The following parameters are automatically adjusted or used as reference when you execute anti-resonance control adjustment.

Do not change the settings while anti-resonance control adjustment is being executed.

Parameter	Name	Automatic Changes
Pn160	Anti-Resonance Control-Related Selections	Yes
Pn161	Anti-Resonance Frequency	Yes
Pn162	Anti-Resonance Gain Correction	No
Pn163	Anti-Resonance Damping Gain	Yes
Pn164	Anti-Resonance Filter Time Constant 1 Correction	No
Pn165	Anti-Resonance Filter Time Constant 2 Correction	No

Yes: The parameter is automatically set.

No: The parameter is not automatically set, but the setting is read during execution.

2.1.6 Suppressing Different Vibration Frequencies with Anti-resonance Control

When you use anti-resonance control and increase the control gain, for some mechanism, vibration can occur at a higher frequency than the frequency for which vibration was suppressed. If this occurs, you can suppress vibration for more than one frequency by adjusting Pn166 (Anti-Resonance Damping Gain 2).

Information

Guideline

Vibration frequencies: 100 to 1,000 Hz (fa and fb)

Range of different vibration frequencies: $1 < (fb/fa) \leq 3$ to 4

Where, fa [Hz] is Pn161 (Anti-Resonance Frequency) and fb [Hz] is the vibration frequency that occurs when the control gain is increased.

Required Parameter Settings

The following parameter settings are required to use anti-resonance control for more than one vibration frequency.

Parameter		Description	When Enabled	Classification		
Pn160	n.□□□0 (default setting)	Do not use anti-resonance control.	After restart	Setup		
	n.□□□1	Use anti-resonance control.				
Pn161	Anti-Resonance Frequency			Speed	Position	Torque
	Setting Range	Setting Unit	Default Setting	When Enabled	Classification	
	10 to 20,000	0.1 Hz	1000	Immediately	Tuning	
Pn162	Anti-Resonance Gain Correction			Speed	Position	Torque
	Setting Range	Setting Unit	Default Setting	When Enabled	Classification	
	1 to 1,000	1%	100	Immediately	Tuning	
Pn163	Anti-Resonance Damping Gain			Speed	Position	Torque
	Setting Range	Setting Unit	Default Setting	When Enabled	Classification	
	0 to 300	1%	0	Immediately	Tuning	
Pn164	Anti-Resonance Filter Time Constant 1 Correction			Speed	Position	Torque
	Setting Range	Setting Unit	Default Setting	When Enabled	Classification	
	-1,000 to 1,000	0.01 ms	0	Immediately	Tuning	
Pn165	Anti-Resonance Filter Time Constant 2 Correction			Speed	Position	Torque
	Setting Range	Setting Unit	Default Setting	When Enabled	Classification	
	-1,000 to 1,000	0.01 ms	0	Immediately	Tuning	
Pn166	Anti-Resonance Damping Gain 2			Speed	Position	Torque
	Setting Range	Setting Unit	Default Setting	When Enabled	Classification	
	0 to 1,000	1%	0	Immediately	Tuning	

Adjustment Procedure for Suppressing Different Vibration Frequencies with Anti-resonance Control

Use the following procedure to make adjustments to suppress different vibration frequencies with anti-resonance control.

Step	Operation
1	Adjust the gain and anti-resonance control with the procedure on page 2-3.
2	If there is vibration at a higher frequency than the vibration suppressed with anti-resonance control in step 1, adjust Pn166 (Anti-Resonance Damping Gain 2).
3	Adjust Pn166 (Anti-Resonance Damping Gain 2) while checking to see if vibration reduction is effective. To adjust Pn166 (Anti-Resonance Damping Gain 2), increase the setting by 10% at a time starting from the value that resulted in Pn163 (Anti-Resonance Damping Gain) from the adjustment in step 1.
4	If the vibration disappears, the adjustment is completed. However, if the vibration does not disappear even when you adjust Pn166 (Anti-Resonance Damping Gain 2), reduce the tuning level or feedback level until vibration does not occur.

2.2 Speed Ripple Compensation

This section describes speed ripple compensation.

This functionality is supported by the following SERVOPACKs.

- Σ -7S SERVOPACKs with Analog Voltage/Pulse Train References
- Σ -7S SERVOPACKs with MECHATROLINK-II Communications References
- Σ -7S SERVOPACKs with MECHATROLINK-III Communications References
- Σ -7W SERVOPACKs with MECHATROLINK-III Communications References

2.2.1 Outline

Speed ripple compensation reduces the amount of ripple in the motor speed due to torque ripple or cogging torque. You can enable speed ripple compensation to achieve smoother operation.

To enable speed ripple compensation, you must set up ripple compensation on the SigmaWin+.



WARNING

- Speed ripple compensation requires operating the motor and therefore presents hazards. Observe the following precaution.
Confirm safety around moving parts.
This function involves automatic operation. Make sure that you can perform an emergency stop (to turn OFF the power supply) at any time.



Important

Execute speed ripple compensation only after adjusting the gains.

- Reset speed ripple compensation after you replace the Servomotor or SERVOPACK.
- Execute speed ripple compensation after jogging to a position that ensures a suitable range of motion.

2.2.2 Setting Up Speed Ripple Compensation

Restrictions

◆ Systems for Which Execution Cannot Be Performed

There are no restrictions.

◆ Systems for Which Adjustments Cannot Be Made Accurately

Systems for which there is not a suitable range of motion

◆ Preparations

Check the following settings before you execute speed ripple compensation.

- The main circuit power supply must be ON.
- The servo must be OFF.
- There must be no alarms or warnings.
- There must be no hard wire base block (HWBB).
- The parameters must not be write prohibited.

Applicable Tools

Tool	Function	Reference
Panel Operator	You cannot execute speed ripple compensation from the Panel Operator.	
Digital Operator	You cannot execute speed ripple compensation from the Digital Operator.	
SigmaWin+	Solutions – Ripple Compensation	 <i>Operating Procedure</i> on page 2-8

Operating Procedure

Use the following SigmaWin+ procedure to set up speed ripple compensation.

1. Select **Solutions - Ripple Compensation** from the menu bar of the Main Window of the SigmaWin+ Σ -7 Component.
2. Click the **OK** Button.

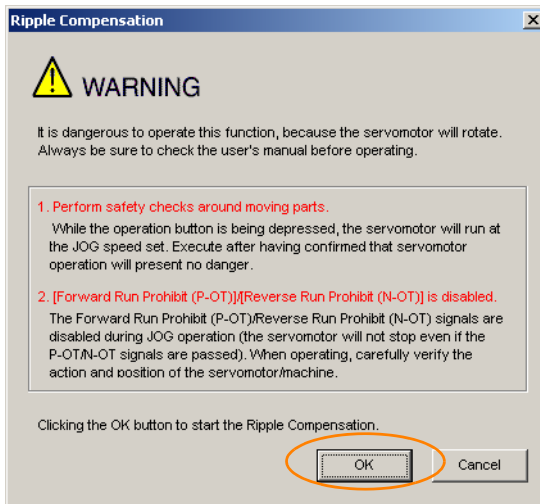

- Information**
1. Click the **Cancel** Button to cancel ripple compensation. The Main Window will return.
 2. If write protection is set, the following dialog box will be displayed.

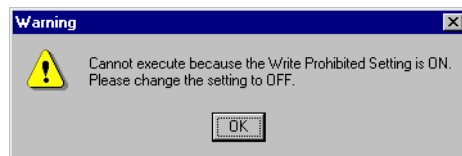

Click the **OK** Button to cancel write prohibition.

3. Click the **Edit Button**.

First, measurement operation is started. The speed for measurement operation is set to the jogging speed.

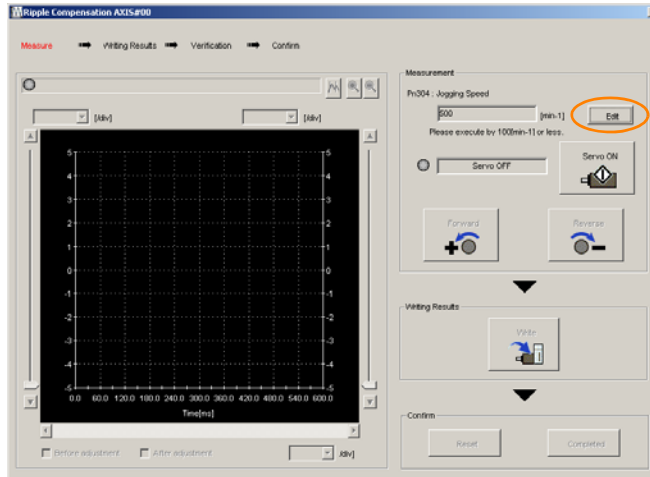

4. Enter the jogging speed for the input value and click the **OK Button**.

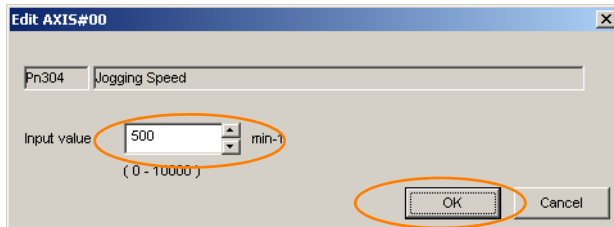

5. Click the **Servo ON Button**.

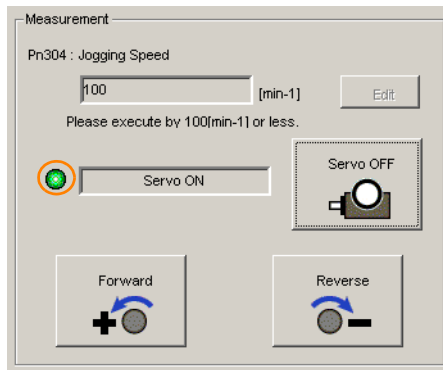

2.2 Speed Ripple Compensation

2.2.2 Setting Up Speed Ripple Compensation

6. Click the **Forward Button** or the **Reverse Button**.

The motor will rotate at the jogging speed while you hold down the **Forward** or **Reverse** Button and the speed ripple will be measured.

The feedback speed and torque reference graph will be displayed in the Tracing Dialog Box during jogging.

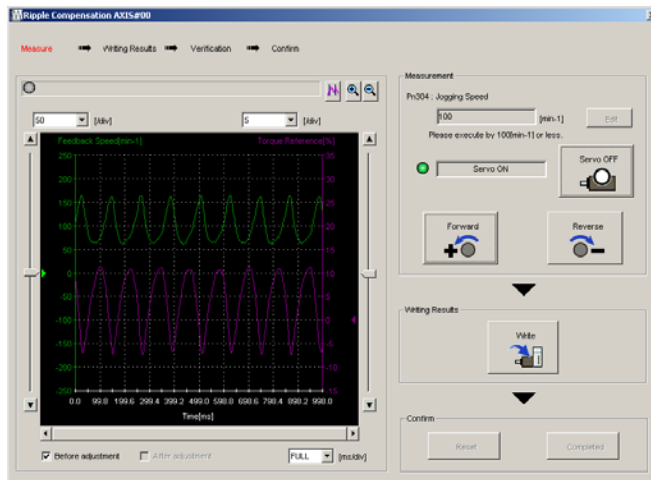

Important

If the measurement time (i.e., the jogging time) for the speed ripple is too short, speed ripple measurement will not be completed. The following dialog box will be displayed if speed ripple measurement was not completed.

Click the **OK** Button and repeat the measurement.

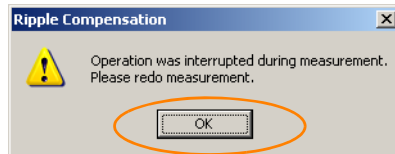

7. After speed ripple measurement has been completed, click the **Write Button**.

The ripple compensation value will be written to the SERVOPACK.

8. After writing has been completed, click the **OK** Button.

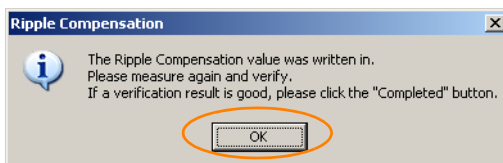

9. Click the **Forward Button** or the **Reverse Button**.

Next, perform verification operation.

The motor will rotate at the jogging speed while you hold down the **Forward** or **Reverse** Button. The waveform with speed ripple compensation applied to it will be displayed.

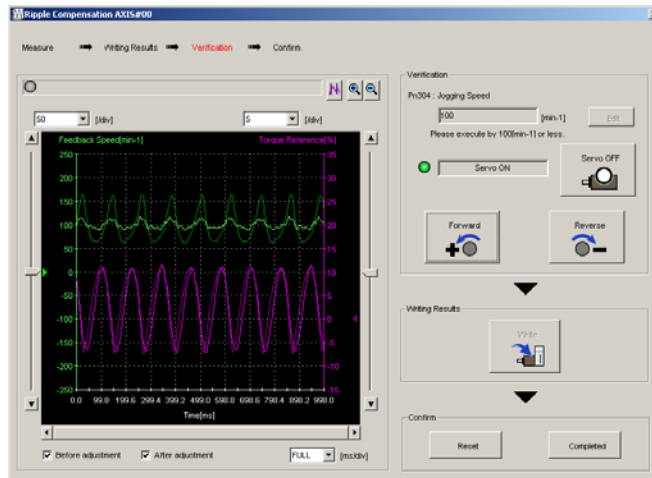

10. If the verification results are OK, click the **Finish Button**.

Information To discard the setup results, click the **Reset** Button.

This concludes the setup for speed ripple compensation.

2.2.3 Setting Parameters

Speed ripple compensation is enabled when you set it up on the SigmaWin+. To cancel speed ripple compensation, use Pn423 = n.□□□X (Speed Ripple Compensation Function Selection) to disable it.

Parameter		Description	When Enabled	Classification
Pn423	n.□□□0 (default setting)	Disable speed ripple compensation.	After restart	Setup
	n.□□□1	Enable speed ripple compensation.		

If you enable speed ripple compensation, a compensation reference will be applied to reduce ripple even when stopped at a 0 speed reference. In speed control mode, this may result in the motor moving slightly. To prevent this, set Pn423 (Speed Ripple Compensation Selections) and Pn427 or Pn49F (Speed Ripple Compensation Enable Speed).

Parameter		Description	When Enabled	Classification
Pn423	n.□0□□ (default setting)	Speed reference	After restart	Setup
	n.□1□□	Motor Speed		

- For Rotary Servomotors

Pn427	Speed Ripple Compensation Enable Speed			Speed	Position	Torque
	Setting Range	Setting Unit	Default Setting	When Enabled	Classification	
	0 to 10,000	1 min ⁻¹	0	Immediately	Tuning	

- For Linear Servomotors

Pn49F	Speed Ripple Compensation Enable Speed			Speed	Position	Torque
	Setting Range	Setting Unit	Default Setting	When Enabled	Classification	
	0 to 10,000	1 mm/s	0	Immediately	Tuning	

2.2 Speed Ripple Compensation

2.2.3 Setting Parameters

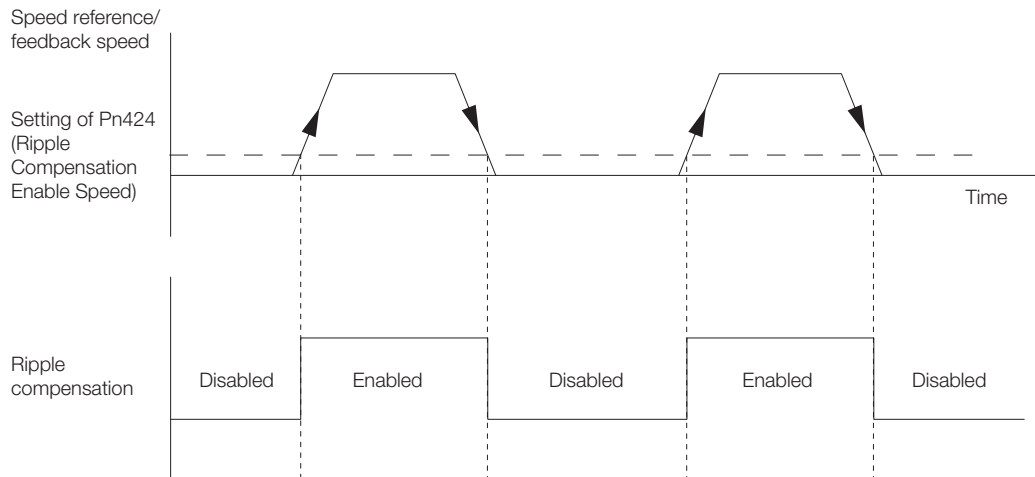

Speed Ripple Compensation Warnings

The speed ripple compensation value is specific to each Servomotor. If you replace the Servomotor while speed ripple compensation is enabled, an A.942 warning (Speed Ripple Compensation Information Disagreement) will occur to warn you.

If an A.942 warning occurs, either reset or disable speed ripple compensation from the SigmaWin+.

You can also disable detection of this warning with the following parameter.

Parameter		Description	When Enabled	Classification
Pn423	n.□□0□ (default setting)	Detect A.942 alarms.	After restart	Setup
	n.□□1□	Do not detect A.942 alarms.		

Monitoring



This chapter provides information on monitoring SERVO-
PACK product information and SERVOPACK status.

3.1	Monitoring Product Life	3-2
3.1.1	Items That You Can Monitor	3-2
3.1.2	Operating Procedure	3-2
3.1.3	Preventative Maintenance	3-3

3.1 Monitoring Product Life

This functionality is supported by the following SERVOPACKs.

- Σ-7S SERVOPACKs with Analog Voltage/Pulse Train References
- Σ-7S SERVOPACKs with MECHATROLINK-II Communications References
- Σ-7S SERVOPACKs with MECHATROLINK-III Communications References
- Σ-7W SERVOPACKs with MECHATROLINK-III Communications References

3.1.1 Items That You Can Monitor

Monitor Items
<ul style="list-style-type: none">• SERVOPACK Installation Environment• Servomotor Installation Environment• Built-in Fan Service Life Prediction• Capacitor Service Life Prediction• Inrush Current Limiting Circuit Service Life Prediction• Dynamic Brake Circuit Service Life Prediction

3.1.2 Operating Procedure

Use the following procedure to display the installation environment and service life prediction monitor dialog box.

- Select **Life Monitor – Installation Environment Monitor** or **Life Monitor – Service Life Prediction Monitor** from the menu bar of the Main Window of the SigmaWin+.

Information With the Panel Operator or Digital Operator, you can use Un025 to Un02A to monitor this information.

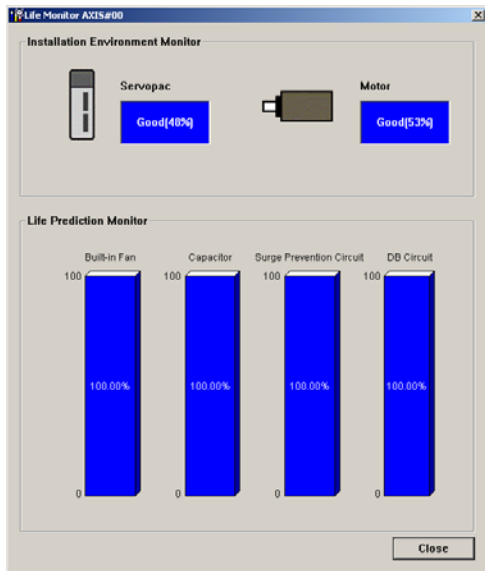

A monitor value of 100% indicates that the SERVOPACK has not yet been used. The percentage decreases as the SERVOPACK is used and reaches 0% when it is time to replace the SERVOPACK.

3.1.3 Preventative Maintenance

You can use the following functions for preventative maintenance.

- Preventative maintenance warnings
- /PM (Preventative Maintenance Output) signal

The SERVOPACK can notify the host controller when it is time to replace any of the main parts.

Preventative Maintenance Warning

An A.9b0 warning (Preventative Maintenance Warning) is detected when any of the following service life prediction values drops to 10% or less: SERVOPACK built-in fan life, capacitor life, inrush current limiting circuit life, and dynamic brake circuit life. You can change the setting of Pn00F = n.□□□X to enable or disable these warnings.

Parameter		Description	When Enabled	Classification
Pn00F	n.□□□0 (default setting)	Do not detect preventative maintenance warnings.	After restart	Setup
	n.□□□1	Detect preventative maintenance warnings.		

/PM (Preventative Maintenance Output) Signal

The /PM (Preventative Maintenance Output) signal is output when any of the following service life prediction values reaches 10% or less: SERVOPACK built-in fan life, capacitor life, inrush current limiting circuit life, and dynamic brake circuit life. The /PM (Preventative Maintenance Output) signal must be allocated.

Even if detection of preventive maintenance warnings is disabled (Pn00F = n.□□□0), the /PM signal will still be output as long as it is allocated.

Classification	Signal	Connector Pin No.	Signal Status	Description
Output	/PM	Must be allocated.	ON (closed)	One of the following service life prediction values reached 10% or less: SERVOPACK built-in fan life, capacitor life, inrush current limiting circuit life, and dynamic brake circuit life.
			OFF (open)	All of the following service life prediction values are greater than 10%: SERVOPACK built-in fan life, capacitor life, inrush current limiting circuit life, and dynamic brake circuit life.

Related Parameters

- Σ-7S SERVOPACKs with Analog Voltage/Pulse Train References

Parameter		Description	When Enabled	Classification
Pn514	n.□□□0 (default setting)	Disabled (the above signal output is not used).	After restart	Setup
	n.□□□1	Output the signal from the CN1-25 or CN1-26 output terminal.		
	n.□□□2	Output the signal from the CN1-27 or CN1-28 output terminal.		
	n.□□□3	Output the signal from the CN1-29 or CN1-30 output terminal.		
	n.□□□4	Output the signal from the CN1-37 output terminal.		
	n.□□□5	Output the signal from the CN1-38 output terminal.		
	n.□□□6	Output the signal from the CN1-39 output terminal.		

- Σ-7S SERVOPACKs with MECHATROLINK-II Communications References or Σ-7S SERVOPACKs with MECHATROLINK-III Communications References

Parameter		Description	When Enabled	Classification
Pn514	n.□□□0 (default setting)	Disabled (the above signal output is not used).	After restart	Setup
	n.□□□1	Output the signal from the CN1-1 or CN1-2 output terminal.		
	n.□□□2	Output the signal from the CN1-23 or CN1-24 output terminal.		
	n.□□□3	Output the signal from the CN1-25 or CN1-26 output terminal.		

- Σ-7W SERVOPACKs with MECHATROLINK-III Communications References

Parameter		Description	When Enabled	Classification
Pn514	n.□□□0 (default setting)	Disabled (the above signal output is not used).	After restart	Setup
	n.□□□1	Axis A: Output the signal from the CN1-23 or CN1-24 output terminal. Axis B: Output the signal from the CN1-25 or CN1-26 output terminal.		
	n.□□□2	Axis A: Output the signal from the CN1-27 or CN1-28 output terminal. Axis B: Output the signal from the CN1-29 or CN1-30 output terminal.		
Pn597	n.□023	Allocate the signal to CN1-23.	After restart	Setup
	n.□025	Allocate the signal to CN1-25.		
	n.□027	Allocate the signal to CN1-27.		
	n.□029	Allocate the signal to CN1-29.		
	n.□031	Allocate the signal to CN1-31.		
	n.0□□□ (default setting)	Disabled (the above signal output is not used).		
	n.1□□□	Output the above signal.		
	n.2□□□	Invert the above signal and output it.		

Maintenance



This chapter provides information on the meaning of, causes of, and corrections for alarms and warnings.

4.1 Alarm Displays 4-2

- 4.1.1 List of Alarms 4-2
- 4.1.2 Troubleshooting Alarms 4-3
- 4.1.3 Resetting Motor Type Alarms 4-3

4.2 Warning Displays 4-5

- 4.2.1 List of Warnings 4-5
- 4.2.2 Troubleshooting Warnings 4-5

4.1 Alarm Displays

If an error occurs in the SERVOPACK, an alarm number will be displayed on the panel display.

- Σ-7S SERVOPACKs with Analog Voltage/Pulse Train References

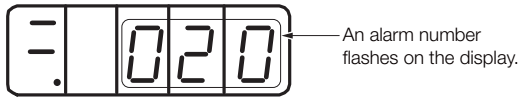

- Σ-7S SERVOPACKs with MECHATROLINK-II Communications References, Σ-7S SERVOPACKs with MECHATROLINK-III Communications References, or Σ-7W SERVOPACKs with MECHATROLINK-III Communications References

If there is an alarm, the display will change in the following order.

Example: Alarm A.E60

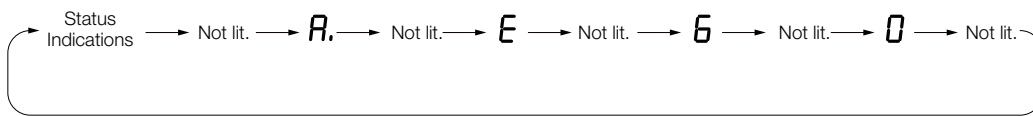

This section provides a list of the alarms that may occur and the causes of and corrections for those alarms.

4.1.1 List of Alarms

The list of alarms gives the alarm name, alarm meaning, alarm stopping method, alarm reset possibility, and alarm code output in order of the alarm numbers.

Servomotor Stopping Method for Alarms

Refer to the following section for information on the stopping method for alarms.

Alarm Reset Possibility

Yes: You can use an alarm reset to clear the alarm. However, this assumes that the cause of the alarm has been removed.

No: You cannot clear the alarm.

Alarms for Both Axes

If “All Axes” is given below the alarm number, the alarm applies to both axes. If an alarm occurs for one axis, the same alarm status will occur for the other axis.

List of Alarms

Alarm Number	Alarm Name	Alarm Meaning	Servo-motor Stopping Method	Alarm Reset Possible?	Alarm Code Output		
					ALO1	ALO2	ALO3
A.070	Motor Type Change Detected	The connected motor is a different type of motor from the previously connected motor.	Gr.1	No	H	H	H

4.1.2 Troubleshooting Alarms

The causes of and corrections for the alarms are given in the following table. Contact your Yaskawa representative if you cannot solve a problem with the correction given in the table.

Alarm Number: Alarm Name	Possible Cause	Confirmation	Correction	Refer- ence for Correction
A.070: Motor Type Change Detected (The connected motor is a differ- ent type of motor from the previ- ously connected motor.)	A Rotary Servomotor was removed and a Linear Servomotor was connected.	–	Set the parameters for a Linear Servomotor and reset the motor type alarm. Then, turn the power supply to the SER- VOPACK OFF and ON again.	page 4-3
	A Linear Servomotor was removed and a Rotary Servomotor was connected.	–	Set the parameters for a Rotary Servomotor and reset the motor type alarm. Then, turn the power supply to the SER- VOPACK OFF and ON again.	page 4-3

4.1.3 Resetting Motor Type Alarms

The SERVOPACK automatically determines the type of motor that is connected to it. If the type of motor that is connected is changed, an A.070 alarm (Motor Type Change Detected) will occur the next time the SERVOPACK is started. If an A.070 alarm occurs, you must set the parameters to match the new type of motor.

An A.070 alarm is reset by executing the Reset Motor Type Alarm utility function.

- Information**
1. This utility function is the only way to reset an A.070 alarm (Motor Type Change Detected). The errors are not reset when you reset alarms or turn OFF the power supply to the SERVOPACK.
 2. If an A.070 alarm occurs, first set the parameters according to the newly connected motor type and then execute the Reset Motor Type Alarm utility function.

This functionality is supported by the following SERVOPACKs.



- Σ -7S SERVOPACKs with Analog Voltage/Pulse Train References
- Σ -7S SERVOPACKs with MECHATROLINK-II Communications References
- Σ -7S SERVOPACKs with MECHATROLINK-III Communications References
- Σ -7W SERVOPACKs with MECHATROLINK-III Communications References

Preparations

Check the following setting before you execute the Reset Motor Type Alarm utility function.

- The parameters must not be write prohibited.

Applicable Tools

Tool	Function	Reference
Panel Operator	Fn021	 <i>Operating Procedure with Panel Operator on page 4-4</i>
Digital Operator	Fn021	 <i>Operating Procedure with Digital Operator on page 4-4</i>
SigmaWin+	Setup – Reset Motor Type Alarm	–

Operating Procedure with Panel Operator

Step	Panel Display after Operation	Keys	Operation
1			Press the MODE/SET Key to enter Utility Function Mode.
2			Press the UP Key or DOWN Key to display Fn021 .
3			Press the DATA/SHIFT Key for approximately one second. The display shown at the left will appear.
4			Press the MODE/SET Key to reset the motor type alarm. donE will flash on the display and the display shown on the left will appear again.
5			Press the DATA/SHIFT Key for approximately one second to return the display to Fn021 .
6	To enable the change to the setting, turn the power supply to the SERVOPACK OFF and ON after you execute the Reset Motor Type Alarm utility function.		

Operating Procedure with Digital Operator

Use the following procedure.

Step	Operation	Result
1	Press the Key to display the Utility Mode Main Menu, and then use the Key or Key to select Fn021 .	<pre>1:A.070 FUNCTION Fn020:S-Orig Set Fn021:Motor Init Fn030:Soft Reset Fn080:Pole Detect</pre>
2	Press the Key.	The Fn021 (Reset Motor Type Alarm) execution display will appear. <pre>1 : A.070 Motor Connect History Init Start : [DATA] Return: [SET]</pre>
3	Press the Key.	The motor type alarm alarm will be reset. When processing has been completed, the status display will flash DONE for approximately one second and then return to 1:A.070 . <pre>1:A.070 Motor Connect History Init Start : [DATA] Return: [SET]</pre>
4	Press the Key.	The display will return to the Utility Mode Main Menu. <pre>1:A.070 FUNCTION Fn020:S-Orig Set Fn021:Motor Init Fn030:Soft Reset Fn080:Pole Detect</pre>
5	Turn the SERVOPACK power supply OFF and ON again.	The parameter setting is now enabled.

4.2 Warning Displays

If a warning occurs in the SERVOPACK, an alarm number will be displayed on the panel display. Warnings are displayed to warn you before an alarm occurs.

This section provides a list of warnings and the causes of and corrections for warnings.

4.2.1 List of Warnings

The list of warnings gives the warning name, warning meaning, and warning code in order of the warning numbers.

If “All Axes” is given below the warning number, the warning applies to both axes. If a warning occurs for one axis, the same warning status will occur for the other axis.

Warning Number	Warning Name	Meaning	Warning Code Output		
			ALO1	ALO2	ALO3
A.942	Speed Ripple Compensation Information Disagreement	The speed ripple compensation information stored in the encoder does not agree with the speed ripple compensation information stored in the SERVOPACK.	H	H	L
A.9b0	Preventative Maintenance Warning	One of the consumable parts has reached the end of its service life.	H	L	H

Note: A warning code is not output unless you set Pn001 to n.1□□□ (Output both alarm codes and warning codes).

4.2.2 Troubleshooting Warnings

The causes of and corrections for the warnings are given in the following table. Contact your Yaskawa representative if you cannot solve a problem with the correction given in the table.

Warning Number: Warning Name	Possible Cause	Confirmation	Correction	Reference
A.942: Speed Ripple Compensation Information Disagreement	The speed ripple compensation information stored in the encoder does not agree with the speed ripple compensation information stored in the SERVOPACK.	–	Reset the speed ripple compensation value on the SigmaWin+.	page 2-8
		–	Set Pn423 to n.□□1□ (Do not detect A.942 alarms). However, changing the setting may increase the speed ripple.	–
		–	Set Pn423 to n.□□□0 (Disable torque ripple compensation). However, changing the setting may increase the speed ripple.	–
A.9b0: Preventative Maintenance Warning	One of the consumable parts has reached the end of its service life.	–	Replace the part. Contact your Yaskawa representative for replacement.	–

Revision History

The revision dates and numbers of the revised manuals are given on the bottom of the back cover.

MANUAL NO. SIEP S800001 50A

Published in Japan May 2014 14-5
└───┬───┬───┬───┬───┬───
Date of original
publication

Date of Publication	Rev. No.	Section	Revised Contents
May 2014	–	–	First edition

Σ -7-Series AC Servo Drive

Σ -7S/ Σ -7W SERVOPACK

Supplementary Manual

IRUMA BUSINESS CENTER (SOLUTION CENTER)

480, Kamifujisawa, Iruma, Saitama 358-8555, Japan
Phone 81-4-2962-5151 Fax 81-4-2962-6138
<http://www.yaskawa.co.jp>

YASKAWA AMERICA, INC.

2121 Norman Drive South, Waukegan, IL 60085, U.S.A.
Phone 1-800-YASKAWA (927-5292) or 1-847-887-7000 Fax 1-847-887-7310
<http://www.yaskawa.com>

YASKAWA ELÉTRICO DO BRASIL LTDA.

Avenida Piraporinha 777, Diadema, São Paulo, 09950-000, Brasil
Phone 55-11-3585-1100 Fax 55-11-3585-1187
<http://www.yaskawa.com.br>

YASKAWA EUROPE GmbH

Hauptstraße 185, Eschborn 65760, Germany
Phone 49-6196-569-300 Fax 49-6196-569-398
<http://www.yaskawa.eu.com>

YASKAWA ELECTRIC KOREA CORPORATION

9F, Kyobo Securities Bldg. 26-4, Yeouido-dong, Yeongdeungpo-gu, Seoul, 150-737, Korea
Phone 82-2-784-7844 Fax 82-2-784-8495
<http://www.yaskawa.co.kr>

YASKAWA ELECTRIC (SINGAPORE) PTE. LTD.

151 Lorong Chuan, #04-02A, New Tech Park 556741, Singapore
Phone 65-6282-3003 Fax 65-6289-3003
<http://www.yaskawa.com.sg>

YASKAWA ELECTRIC (CHINA) CO., LTD.

12F, Carlton Bld., No.21 HuangHe Road, HuangPu District, Shanghai 200003, China
Phone 86-21-5385-2200 Fax 86-21-5385-3299
<http://www.yaskawa.com.cn>

YASKAWA ELECTRIC (CHINA) CO., LTD. BEIJING OFFICE

Room 1011, Tower W3 Oriental Plaza, No.1 East Chang An Ave.,
Dong Cheng District, Beijing 100738, China
Phone 86-10-8518-4086 Fax 86-10-8518-4082

YASKAWA ELECTRIC TAIWAN CORPORATION

9F, 16, Nanking E. Rd., Sec. 3, Taipei 104, Taiwan
Phone 886-2-2502-5003 Fax 886-2-2505-1280



YASKAWA ELECTRIC CORPORATION

In the event that the end user of this product is to be the military and said product is to be employed in any weapons systems or the manufacture thereof, the export will fall under the relevant regulations as stipulated in the Foreign Exchange and Foreign Trade Regulations. Therefore, be sure to follow all procedures and submit all relevant documentation according to any and all rules, regulations and laws that may apply.

Specifications are subject to change without notice for ongoing product modifications and improvements.

© 2014 YASKAWA ELECTRIC CORPORATION. All rights reserved.

MANUAL NO. SIEP S800001 50A

Published in Japan May 2014 14-5

13-6-9

Original instructions